

Audio precision[®] **SWR-2755 Series Audio Switchers**



- Expand analyzer and generator capability up to 192 inputs and outputs.
- Balanced (XLR) and Unbalanced (BNC) connector versions available.
- Crosstalk < -150 dB @ 20 kHz, balanced.

The SWR-2755 family of programmable switchers are accessory units for most of Audio Precision's audio analyzers, including the 2700 series, ATS-2, System One, System Two, System Two Cascade and Cascade *Plus* instruments.

When used without a switcher, these instruments can provide two analog outputs and two analog inputs. A programmable switcher such as the SWR-2755 can be used to expand the two-channel input and output to interface to multi-channel devices or production "bed-of-nails" test fixtures.

SWR-2755 switchers use highly reliable electromechanical relays to best preserve the signal integrity of the generator and signals from the device under test (DUT) for transparent operation. Unlike conventional industrial audio signal routing switchers, the SWR-2755 achieves ex-

ceptional crosstalk performance, less than -150 dB at 20 kHz in balanced operation.

The switchers are controlled by our proprietary APIB interface, and the switcher operation is integrated into Audio Precision's AP2700, ATS, APWIN and S1.exe control software. Channel-in-use LEDs next to each connector indicate crosspoint activity.

There are three versions of SWR-2755 switchers that differ from one another in connector configuration. These are:

- SWR-2755M, front panel fitted with 12 XLR male connectors and 2 XLR female connectors, typically used as an output switcher;
- SWR-2755F, front panel fitted with 12 XLR female connectors and 2 XLR male connectors, typically used as an input switcher; and

- SWR-2755U, front panel fitted with 14 BNC connectors. The “U” or “unbalanced” switchers can appear to the control software as either an input or an output switcher, according to the position of a rear-panel switch.

An output switcher (either an SWR-2755M or an output-configured SWR-2755U) is used to connect the instrument generator outputs to multiple DUT (device under test) inputs. An input switcher (either an SWR-2755F or an input-configured SWR-2755U) is used to connect multiple DUT outputs to the instrument analyzer inputs.

The core of each switcher is a balanced 12 x 2 crosspoint matrix. Either of the two common points can be connected, under software control, to any of the twelve selectable points. The internal circuits are of balanced design but may be used with unbalanced circuits in the BNC connector version, which is implemented with floating (ungrounded)

connector shells. Up to 16 switchers of any configuration can be used in a system, enabling testing of DUTs with a total of up to 192 inputs and/or outputs (up to 96 stereo pairs). Additional switchers are “daisy-chained” on the APIB bus. Configuration switches on the SWR-2755 rear panel enable setting the APIB address of each switcher to the desired channel number selections: 1–12, 13–24, etc. The contacts shown in the diagrams as single switches are actually multiple relay contacts connected in a more complex arrangement. This is necessary to obtain the isolation and crosstalk required for practical professional and high-quality consumer applications.

The SWR-2755 is identical in features to the discontinued SWR-2122 family of switchers, with improved performance.

SWR-2755M output switcher

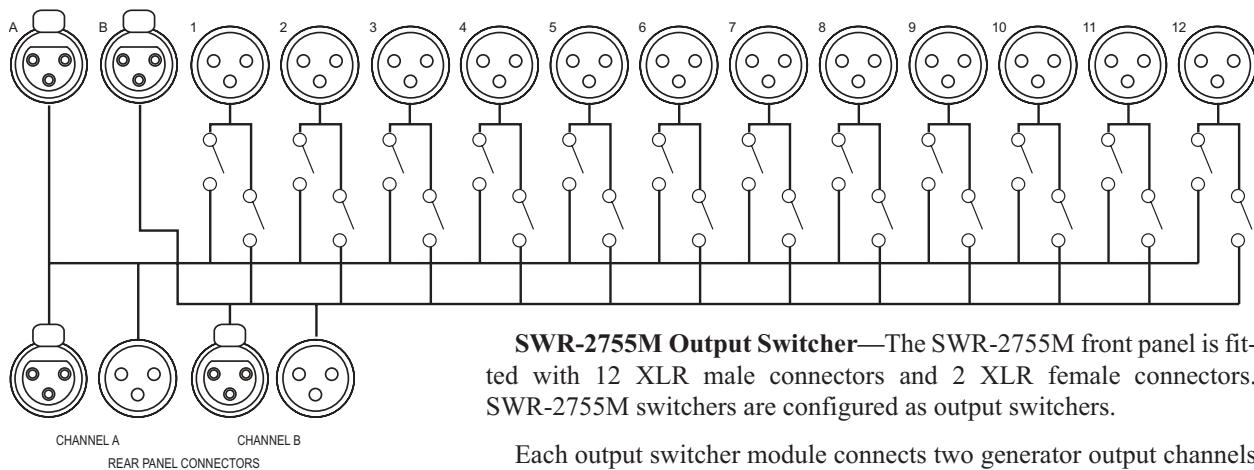
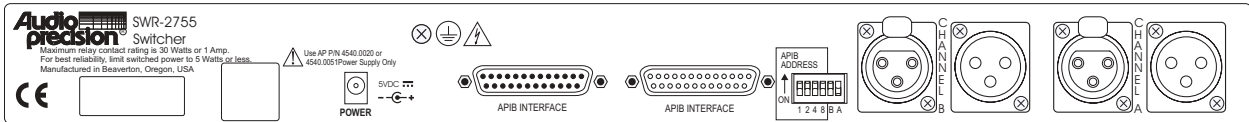
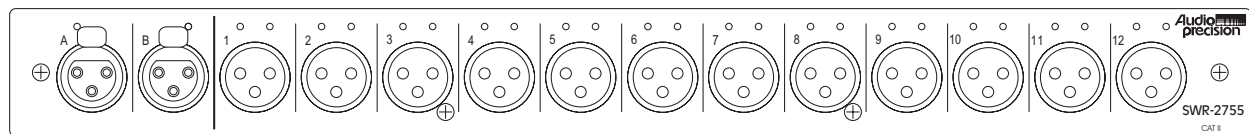

SWR-2755F input switcher

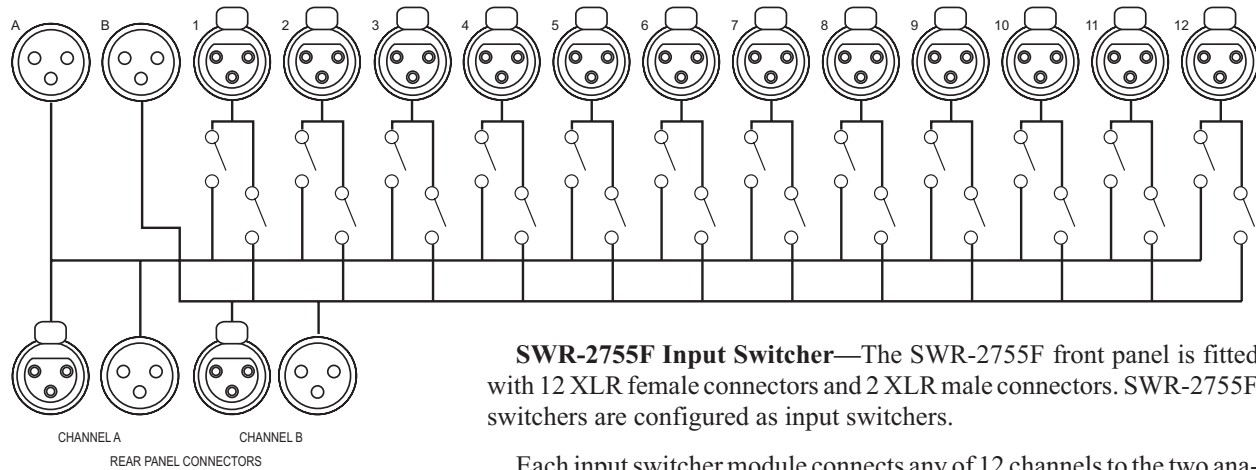
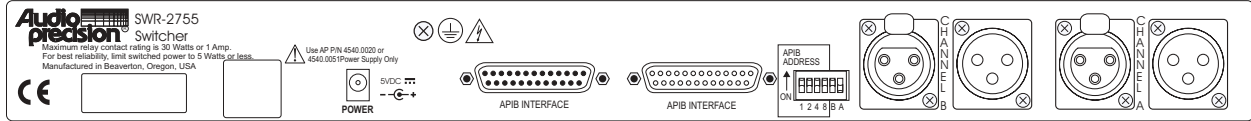
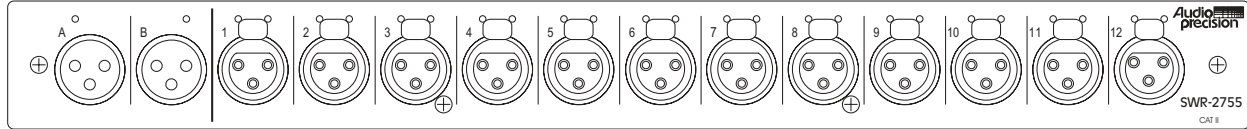

SWR-2755F Input Switcher—The SWR-2755F front panel is fitted with 12 XLR female connectors and 2 XLR male connectors. SWR-2755F switchers are configured as input switchers.

Each input switcher module connects any of 12 channels to the two analyzer input channels (A & B).

SWR-2755U unbalanced switcher

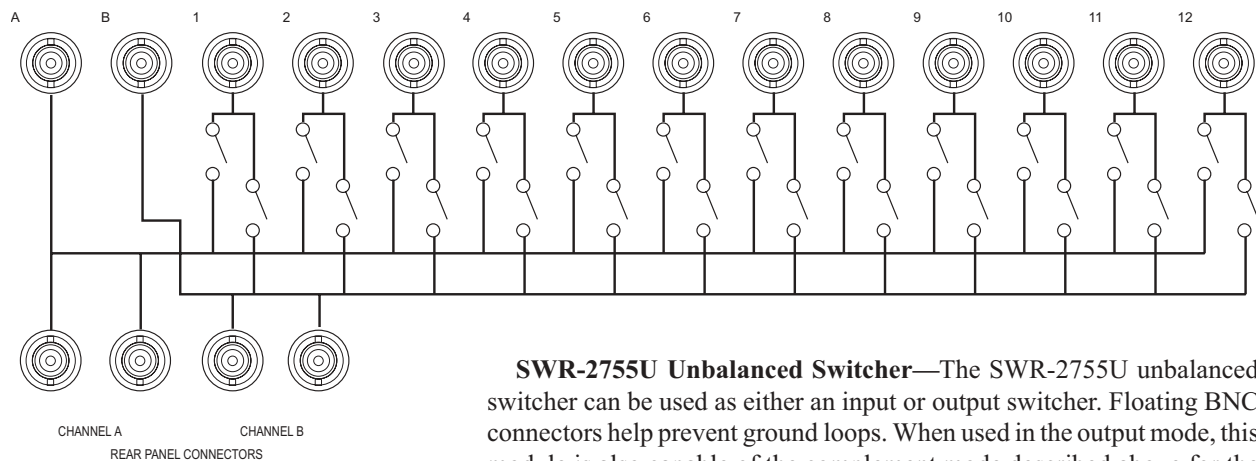
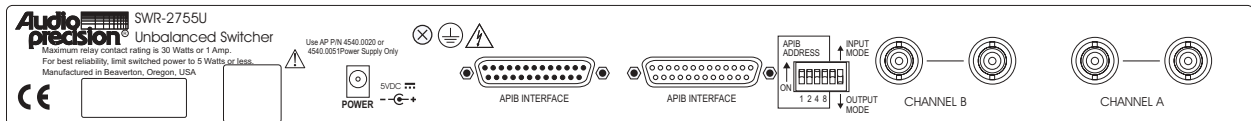
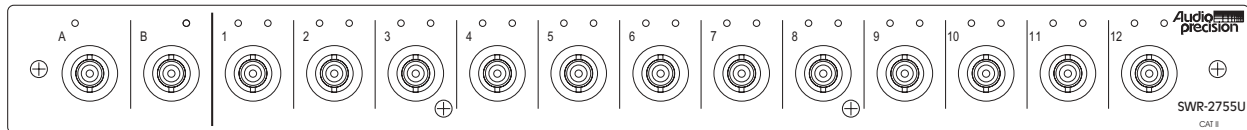

SWR-2755U Unbalanced Switcher—The SWR-2755U unbalanced switcher can be used as either an input or output switcher. Floating BNC connectors help prevent ground loops. When used in the output mode, this module is also capable of the complement mode described above for the SWR-2755M.

Specifications (all models)

Electrical Characteristics

Max Voltage Rating	200 Vpk, 160 Vrms.
Max Signal Power ¹	5 W or 200 mA.
Crosstalk ²	
Balanced 600 Ω load (F and M versions only)	–150 dB @ 20 kHz. –136 dB @ 100 kHz.
Unbalanced 600 Ω load (all versions)	–138 dB @ 20 kHz. –124 dB @ 100 kHz.
Series Resistance	Typically <0.3 Ω per side.
Shunt Capacitance	Typically <90 pF from signal path to chassis (100 nF from BNC shell to chassis on U versions).
Reverse Termination (M version only)	604 Ω , 250 mW maximum.

General Characteristics

Power Requirements	90–250 Vac, 50–60 Hz (via external dc supply module).
Temperature Range	
Operating	0° C to +50° C.
Storage	–40° C to +75° C.
Humidity	80% RH to +40° C (non-condensing).
Altitude	0–2000 m.
Dimensions	16.5" \times 1.75" \times 10.5" [41.9 cm \times 4.4 cm \times 26.7 cm].
Weight	Approximately 9.9 lbs [4.5 kg].

Regulatory Compliances

- EMC³ complies with FCC Part 15 Subpart J (class B), 89/336/EEC, 92/31/EEC, and 93/68/EEC, EN 50081-1 (1992) Emissions Class B, EN-50082-1 (1992) Immunity.
- Safety complies with 73/23/EEC, 93/68/EEC, EN6010-1 (1903)—IEC 1010-1 (1990) + Amendment 1 (1992) + Amendment 2 (1995).
- Installation category II—Pollution Degree 2.
- External Power Supply AP part number 4540.0020 complies with IEC 60950:1991+A1+A2+A3+A4, UL 950 Third Edition E183744, CSA C22.2 No. 950.

External Power Supply AP part number 4540.0051 complies with IEC 60950:1991, UL60950 Third Edition E199447, CSA C22.2 No. 60950, PSE J60950:1998, NOM-001-SCFI-1993.

Mounting

All switchers occupy one rack unit (RU) of height, 1.75 inches. Switchers are provided with feet for tabletop use. They can be rack mounted using the optional rack mount adapter available from Audio Precision, part number RAK-212. These adapters enable either conventional flush-front mounting or recessed mounting (to prevent the front connectors from protruding from the rack).



5750 SW Arctic Drive
Beaverton, Oregon 97005
Tel: 503-627-0832
Fax: 503-641-8906
US Toll Free: 1-800-231-7350
email: info@audioprecision.com
Web: audioprecision.com

¹ Relay contact life decreases very rapidly with increasing switched power. Under no circumstances should the switched power exceed 30 W or 1 A.

² Measured between any two selectable channels into the specified load impedance.

³ Emission and Immunity levels are influenced by the shielding performance of the connecting cables. The shielding performance of the cable will depend on the internal design of the cable, connector quality, and the assembly methods used. EMC compliance was evaluated using Audio Precision XLR type cables, part number 4155.0117.